

CEILING SYSTEMS

[Between us, ideas become reality.]

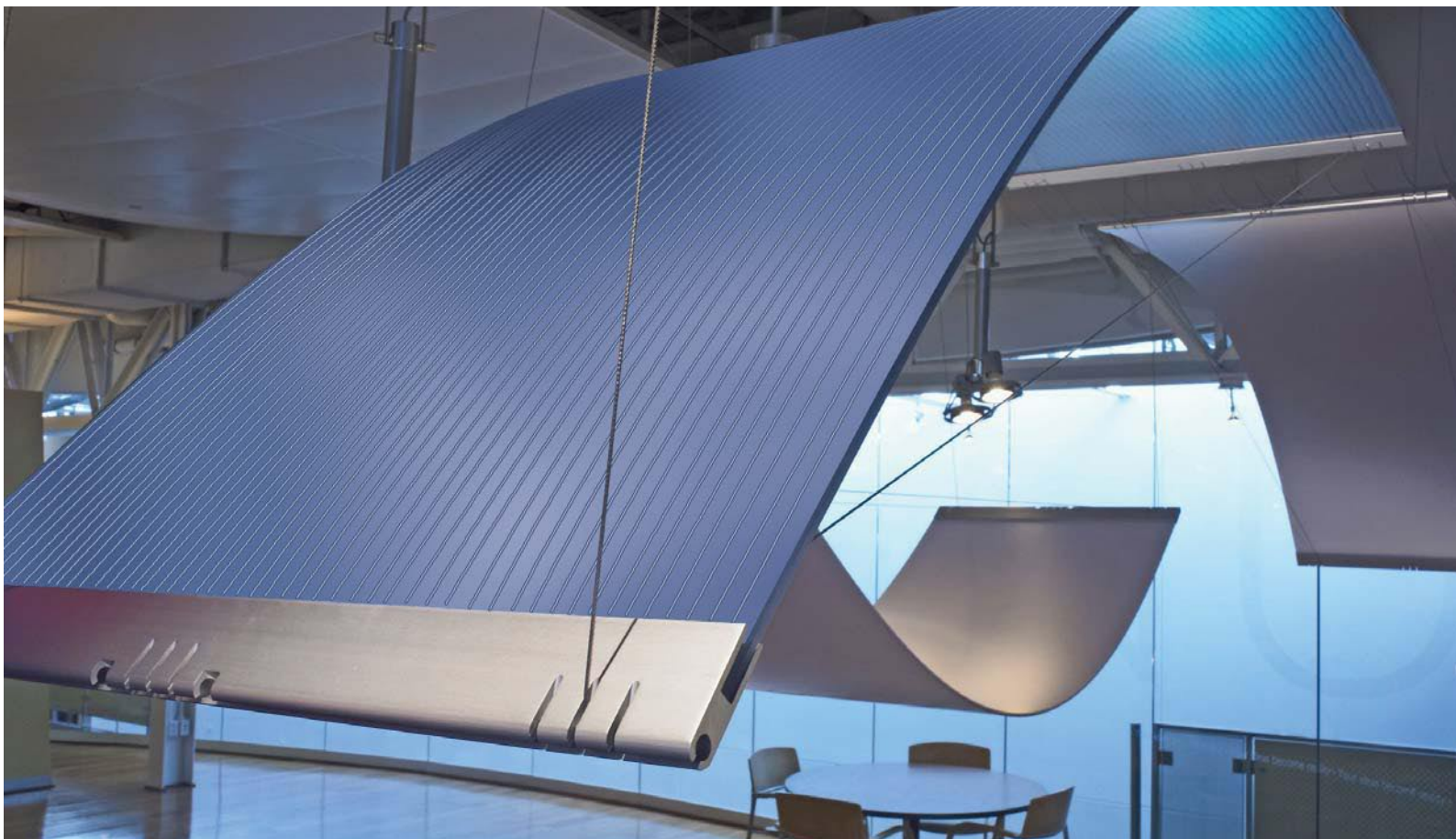

INFUSIONS™ Canopy

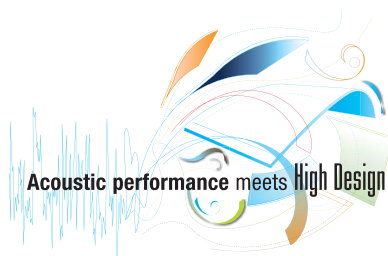



dream

Accentuate an area. Direct the eye. Or provide a touch of intimacy, Infusions™ lets you express your creativity in a whole new dimension.

Anchored to the ceiling or wall with a uniquely simple cable system, Infusions hover in seeming defiance of gravity. Create sculptural configurations - from simple accents to signature statements - in a variety of interesting colours, sizes and textures. With Infusions you can achieve an exciting custom look using standard components.

express

There are so many ways to express yourself with Infusions. In addition to an array of materials, sizes, colours and textures - the placement, configuration and lighting options available make Infusions an invaluable tool for architects and interior designers alike. They are like three-dimensional building blocks that allow your creativity to soar.

Available in 1525 mm and 1830 mm lengths and 610 mm wide, Infusions provide an ingenious way to define zones of various sizes for a variety of purposes - from offering a relaxing respite to affording a comfortable refuge to setting an idyllic mood.

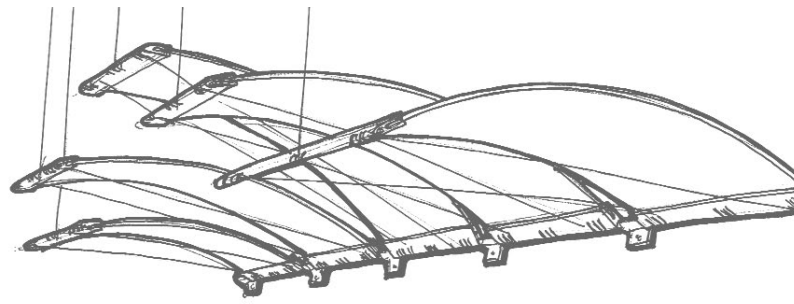

accentuate

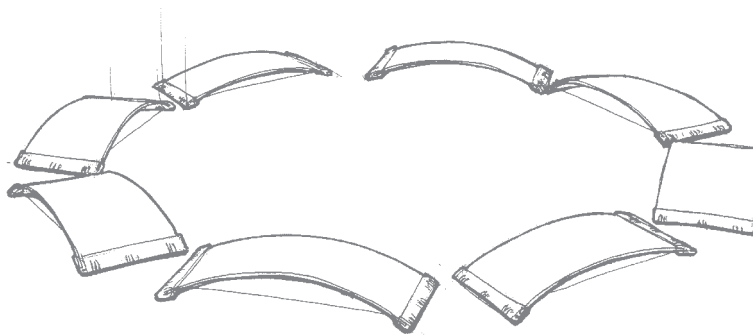
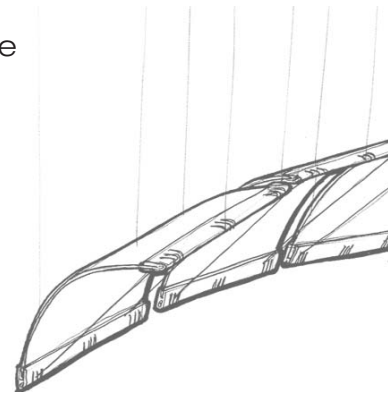

encircle

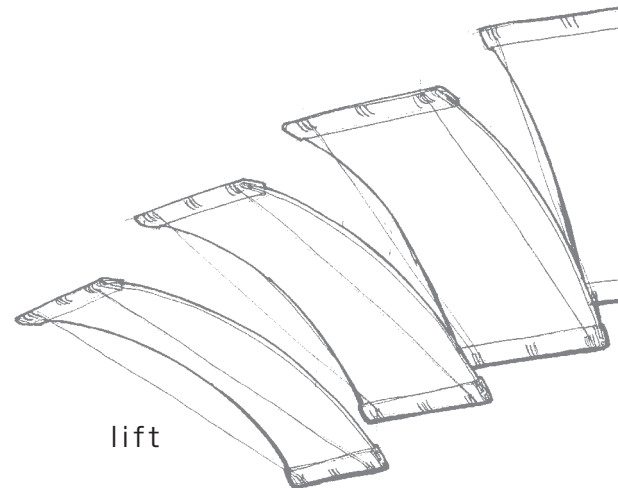

lift

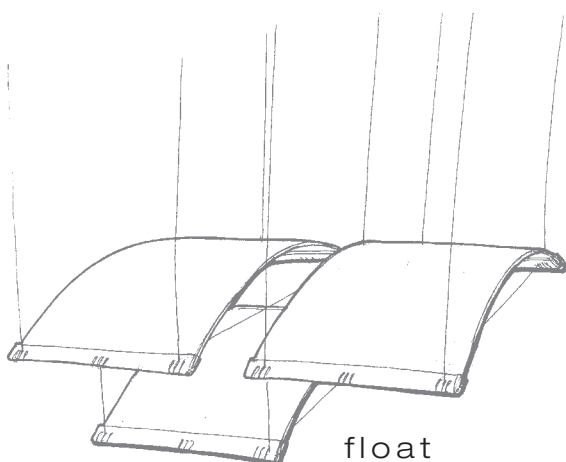

float

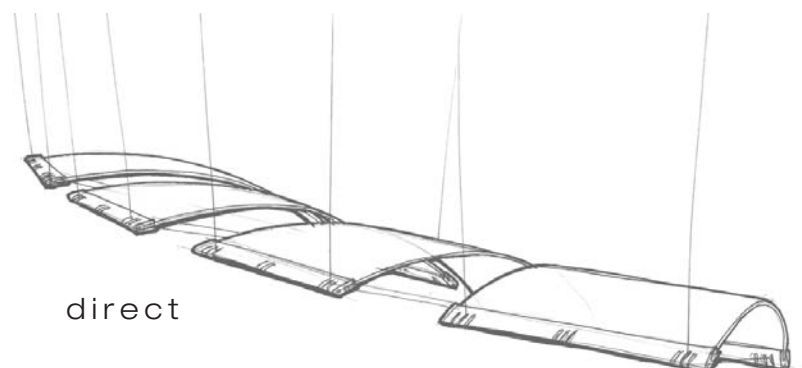

direct

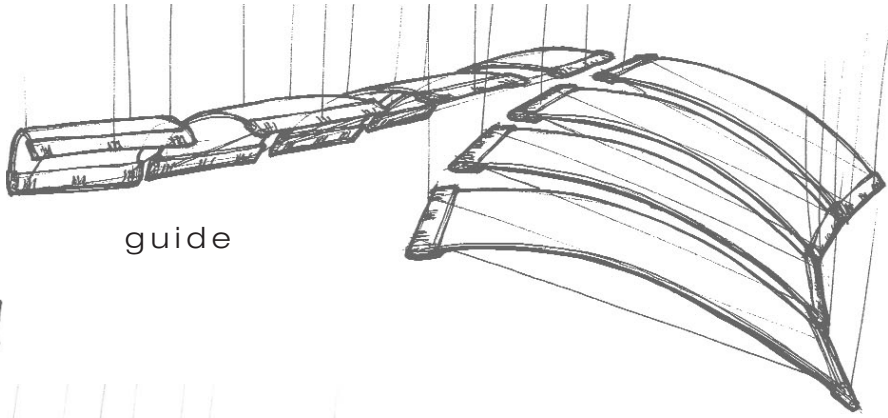

guide

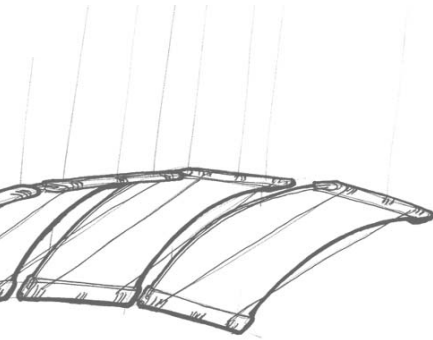

wrap

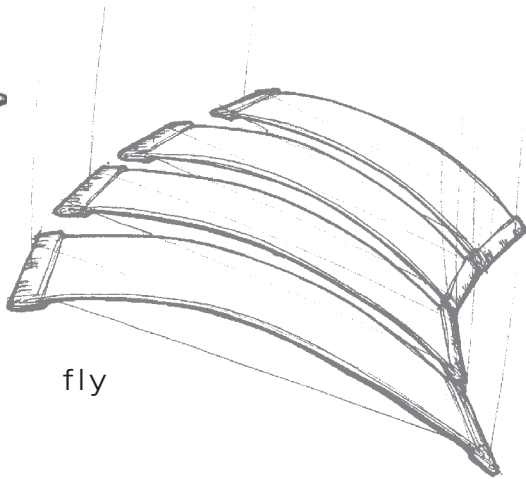

fly

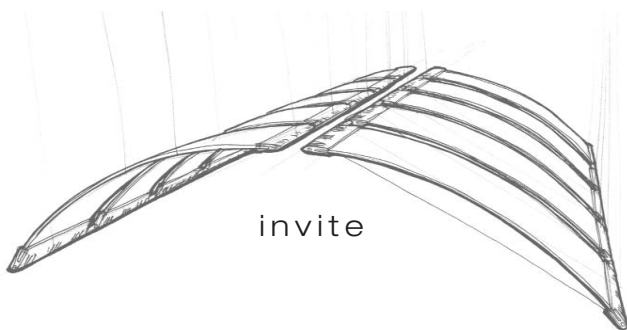

invite

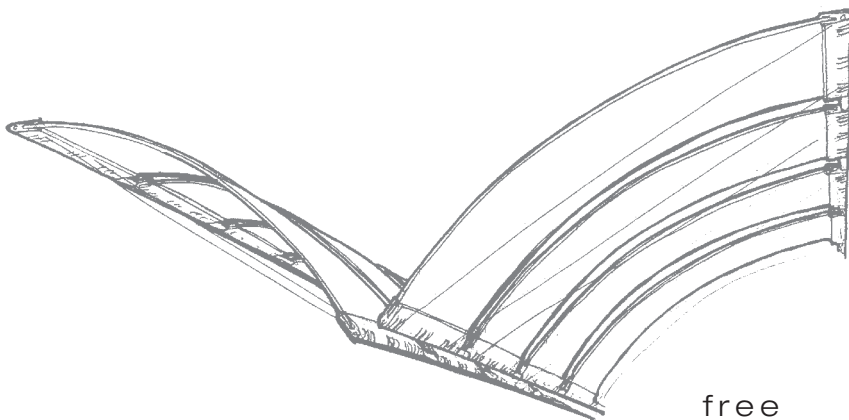

free

Material: Polycarbonate
Surface finish: Smooth
Colours: 6
Sizes: 1525 mm x 610 mm
 1830 mm x 610 mm
Edges: Square
Key selection attributes:

- Canopies can be used to define spaces, accentuate an area, provide focus, create ceiling sculptures
- Standard components allow for custom configurations
- Combine sizes, shapes, textures and finishes
- Use individually or in groups, convex or concave, radius 60 or 90 degrees
- Suspended from the ceiling plenum or wall with a simple cable system
- Lighting can enhance impact
- Durable, washable, scrubbable (non-abrasive cloth), impact resistant
- Fast and simple installation - no special tools required
- Easy-to-order kits provide all the hardware needed

Typical applications: High visibility and focus areas including hospitality, retail, offices, lobbies, atriums, open plenum areas, corridors, airports and transportation

Fire performance level: See Data Sheet

Above dimensions are approximate

Infusions accent canopies are typically made by infusing fabric of varying colour, texture and translucency between layers of polycarbonate resin

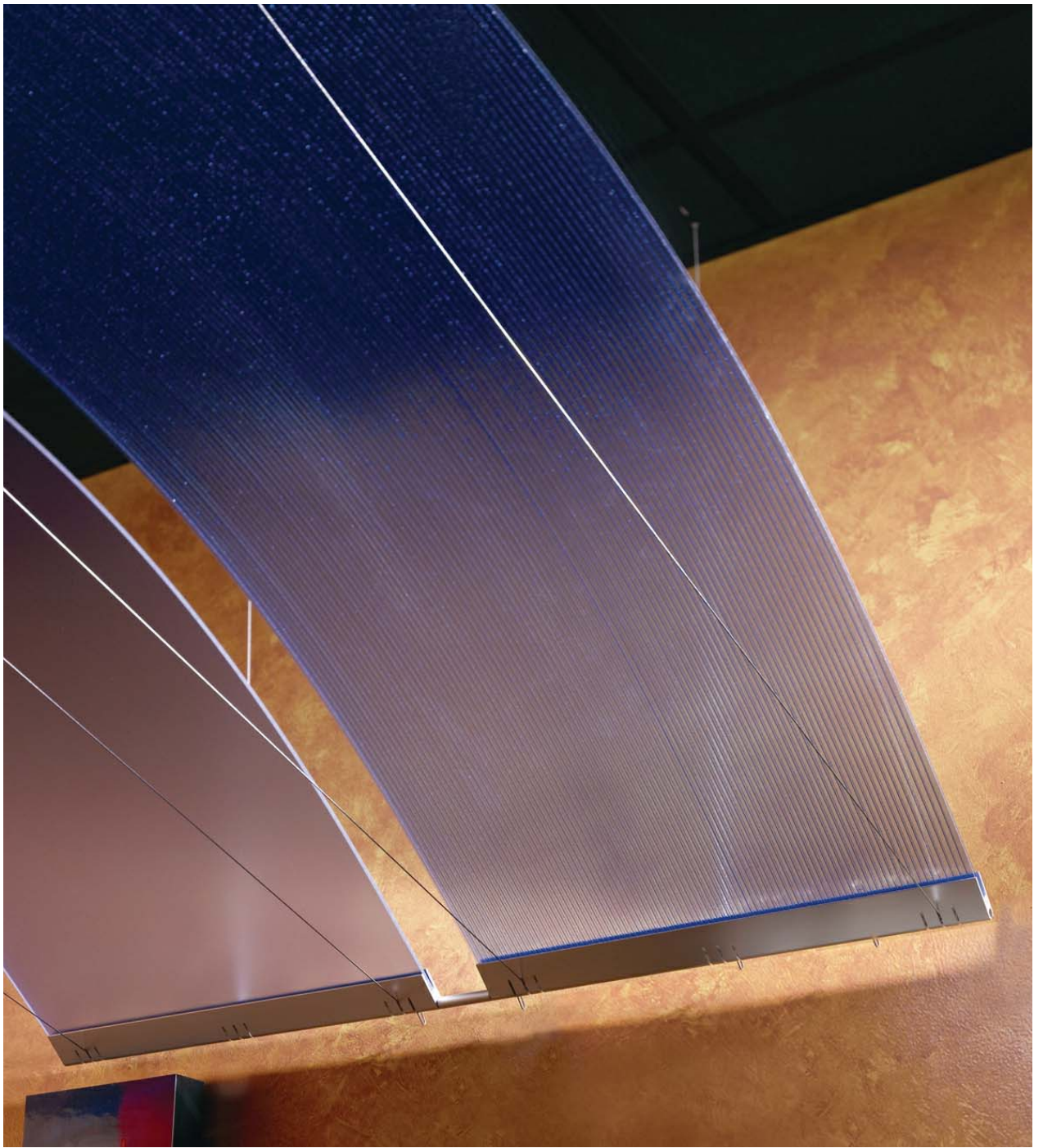

accentuate

Infusions can help define or add visual interest to a small space in any environment. Its rhythmic sculptural form comes alive with different colours, configurations and lighting treatments. The possibilities are endless when using Infusions to accentuate your design ideas. Now it's easy to turn ordinary spaces into extraordinary places.



INFUSIONS™ Canopy



Channelled Mist

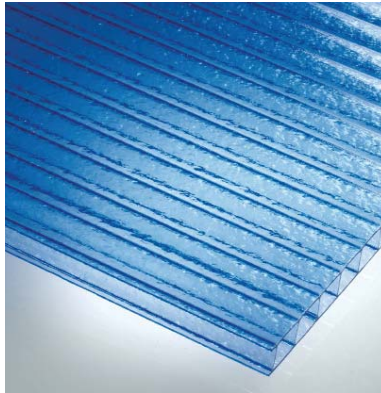

Channelled Midnight

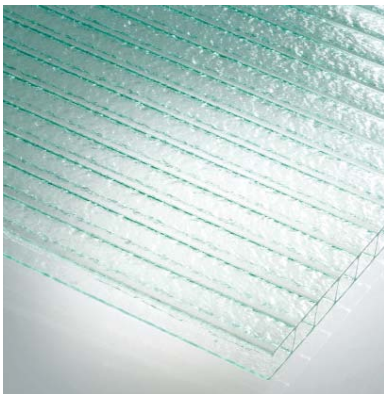

Channelled Caribbean



Channelled Intellect



Channelled Sunset



Channelled Vision

United Kingdom
Republic of Ireland
Armstrong World Industries Ltd.
Building Products Division
Armstrong House
38 Market Square
Uxbridge UB8 1NG
0800 371849 (UK) **FREEPHONE**
1800 409002 (ROI)
Fax: 00 44 (0) 1895 274287
www.armstrong-ceilings.co.uk
sales-support@armstrong.com

Advisory note

All photographic and design elements supplied in this brochure do not necessarily reflect any recommendation by any of the companies named in this brochure as to the proper use or recommended methods of installation of suspended ceilings and are supplied only as informative material.

For technical reasons in printing, differences may appear between colours printed in this brochure and the actual product. The choice of colours should always be made from a sample of the product.

All statements and technical information contained in this brochure, or any publication of the companies named in this brochure, relating to Armstrong ceilings are based on results obtained under laboratory test conditions. It is the responsibility of the user to verify with the seller of the products in writing that such statements and information are appropriate to the specific use intended. Sales of the products and liability of the selling companies are in accordance with the terms and conditions of sale of the selling company.

All product specifications are subject to modifications without prior notice.

1

- (UK) PANEL COMPONENTS (E) ELEMENTOS DE
(F) COMPOSANTS POUR UN FIJACIÓN DE UN PANEL
PANNEAU (D) PANEEL KOMPONENTEN
(I) COMPONENTI DEL (NL) PANEELCOMPONENTEN
PANNELLO

- (UK) Kit A: Infusions Canopy Panel Kit
(F) Kit A: Kit Principal Infusions Canopy
(I) Kit A: Kit principale Infusions Canopy
(E) Kit A: Kit principal Infusions Canopy
(D) Set A: Basis Set
(NL) Kit A: Standaard kit voor een Infusions Canopy paneel

- (UK) (1) Flat Infusions Panel with extrusions attached
(F) (1) Panneau Infusions plat avec cornières en aluminium
(I) (1) Pannello Infusions piano con cornici in alluminio
(E) (1) Panel Infusions plano con remates de aluminio
(D) (1) Flaches Infusions Paneel mit Endschiene
(NL) (1) Infusions paneel met aangebrachte extrusies

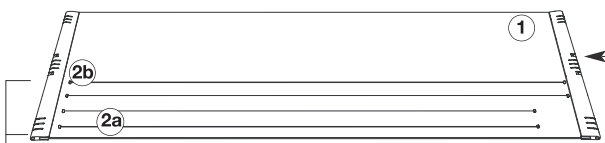

- (UK) (2a) & (2b) Cables to form arcs (60° or 90°)
(F) (2a) & (2b) Câbles permettant de former les arcs (60° ou 90°)
(I) (2a) & (2b) Cavi per creare la curva (60° o 90°)
(E) (2a) & (2b) Cables para dar curvatura al panel (60° ó 90°)
(D) (2a) & (2b) Spannkabel zum erstellen der Bögen (60° oder 90°)
(NL) (2a) & (2b) Kabels om bogen te vormen (60° of 90°)

Infusions				
		1525 mm x 610 mm	1830 mm x 610 mm	
60°	2a	1473 mm	1770 mm	
90°	2b	1400 mm	1670 mm	

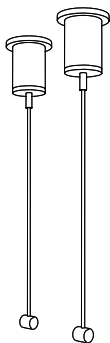

- (UK) Kit B - Standard 2.4m Hanging Kit - BP 7004A
(F) Kit B - Kit d'accrochage standard de 2.4m - BP 7004A
(I) Kit B - Kit di sospensione standard da 2.4m - BP 7004A
(E) Kit B - Kit de suspensión estándar 2.4m - BP 7004A
(D) Set B - Standard 2.4m Aufhängeset - BP 7004A
(NL) Kit B - Ophangkit ter verlenging (2.4m) - BP 7004A

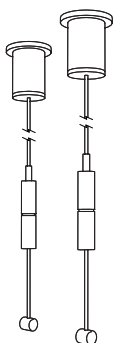

- (UK) Kit C - Extended 4.8m Hanging Kit - BP 7005A
(F) Kit C - Kit d'accrochage de grande hauteur (4.8m) - BP 7005A
(I) Kit C - Kit di estensione da 4.8m - BP 7005A
(E) Kit C - Kit de suspensión gran longitud (4.8m) - BP 7005A
(D) Set C - Extralanges Aufhängesets (4.8m) - BP 7005A
(NL) Kit C - Ophangkit ter verlenging (4.8m) - BP 7005A

2

- (UK) PANEL PREPARATION (E) PREPARACIÓN DEL PANEL
(F) PRÉPARATION DES (D) PANEEL MONTAGE
PANNEAUX (NL) PANEEL VOORBEREIDING
(I) PREPARAZIONE DEL PANNELLO

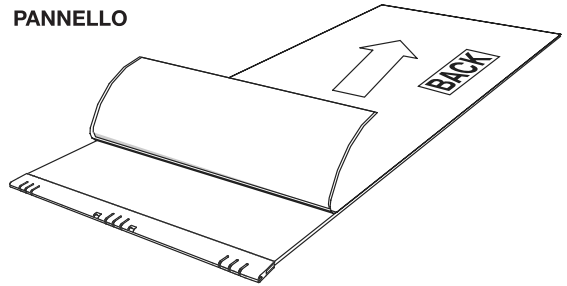

3

- (UK) PANEL ASSEMBLY (E) MONTAJE DEL PANEL
(F) ASSEMBLAGE DES (D) ERSTELLEN DES BOGENS
PANNEAUX (NL) BOGEN CREËREN
(I) ASSEMBLARE I PANNELLI

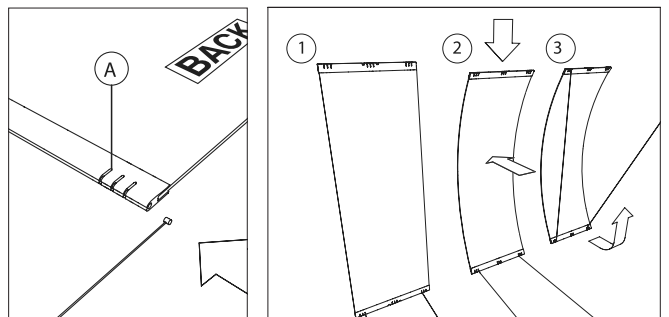
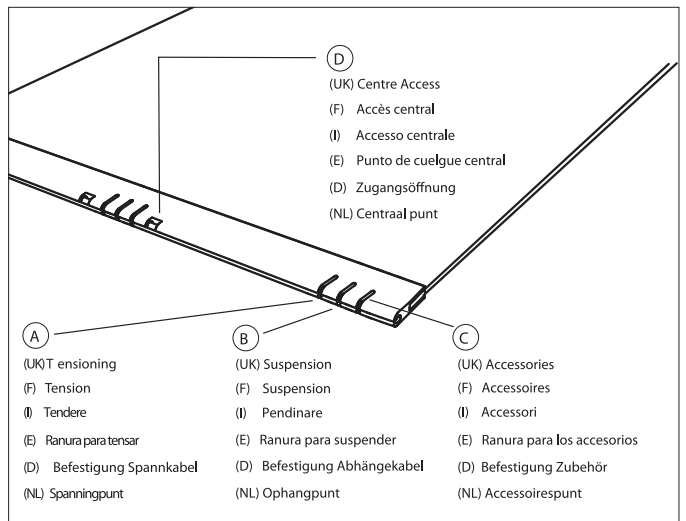

- (UK) Only use cables from Kit A for tensioning panels (Kit B and C are **only** for hanging panels).
(F) Utiliser les câbles provenant des Kit A pour cintrer les panneaux (les kits B et Kits C servent seulement à les suspendre).
(I) Utilizzare **solo** i cavi del kit A per tendere i pannelli. (i kit B e C vengono utilizzati solo per sospendere i pannelli).
(E) Para tensar el panel debe **IMPERATIVAMENTE** utilizarse los cables del Kit A (los cables del Kit B y Kit C son para la suspensión).
(D) Nutzen Sie **nur** die Kabel aus Set A um die Panele zu spannen (Set B und C sind **nur** um die Panele aufzuhängen).
(NL) Gebruik voor het spannen van panelen uitsluitend kabels uit Kit A (de kabels uit Kit B en C zijn uitsluitend bestemd voor het ophangen van panelen).

4

- (UK) INSERTING SUSPENSION CABLES
- (F) INSERER LES CABLES DE SUSPENSION
- (I) INSERIRE I CAVI DI SOSPENSIONE
- (E) MONTAJE DEL CABLE DE SUSPENSIÓN
- (D) VERBINDEN DER ABHÄNGEKABEL
- (NL) HET BEVESTIGEN VAN DE OPHANGKABELS

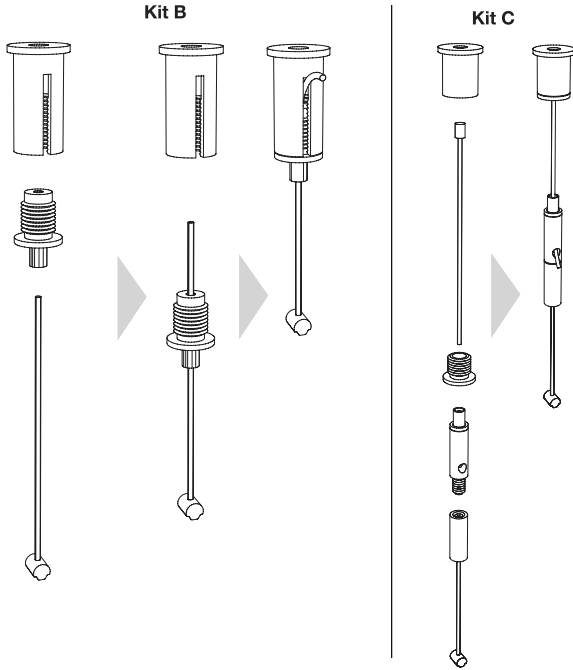

- (UK) The maximum allowable deflection is 5 degrees. Substitute Kit C when cables meet the structure at an angle.
- (F) Un angle de 5° maximum est autorisé. Au delà, il convient d'utiliser un Kit C, si les câbles sont en contact avec la structure.
- (I) La freccia massima è di 5 gradi. Al di sopra, si consiglia di utilizzare il Kit C quando i cavi vengono a contatto con la struttura.
- (E) La máxima desviación permitida con respecto al eje vertical es de 5 grados. Más allá, se recomienda utilizar el kit C, cuando los cables se fijan al forjado en un ángulo.
- (D) Bei Set B dürfen die Kabel nur lotrecht an die Befestigungshülsen anschließen. Die maximale Abweichung ist 5 Grad. Set C ist zu benutzen, wenn das Kabel mit einer größeren Abweichung am Befestigungspunkt anschließt.
- (NL) Bij gebruik van kit B moeten de kabels mogen loodrecht hangen. De maximale toegestane hoek is 5°. Vervang Kit B door Kit C als de hoek groter is.

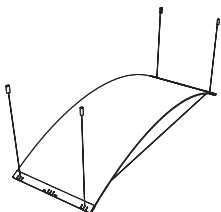
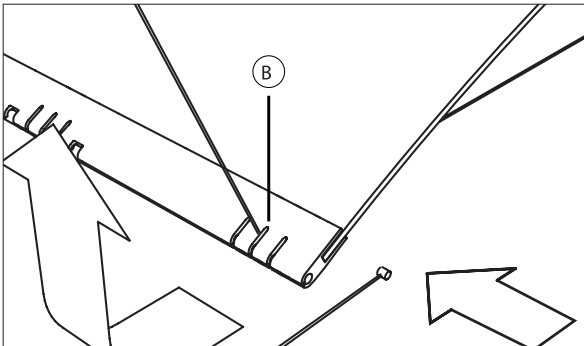

5

- (UK) ATTACHING CANOPIES TO THE STRUCTURE – TWO METHODS*
*NOTE: Fasteners required for attachment to the structure are not included in any Infusions kits since the type required will vary by building structure.
- (F) FIXATION DES INFUSIONS CANOPIES À LA STRUCTURE – 2 MÉTHODES*
*Nota: Les suspentes ne sont pas fournies dans les Kits Infusions, celles-ci pouvant être différentes en fonction du type de structure du bâtiment.
- (I) PENDINARE I CANOPIES ALLA STRUTTURA – DUE METODI*
*NOTA BENE: Gli accessori necessari per pendinare i canopies alla struttura non sono inclusi nel kit di installazione - in quanto dipendenti dal tipo di dalla struttura.
- (E) FIJACIÓN AL FORJADO – DOS MÉTODOS*
*NOTA: Las piezas de cuelgue necesarias para la fijación al forjado no forman parte de los elementos entregados en los Kits puesto que estas piezas pueden variar según la estructura del edificio.
- (D) BEFESTIGUNG DER DECKENSEGEL AN DER TRAGSTRUKTUR – ZWEI MÖGLICHKEITEN*
*HINWEIS: Befestigungsmittel für die Montage an der Tragstruktur werden nicht mitgeliefert da sie unterschiedlich sein können.
- (NL) DE CANOPIES BEVESTIGEN AAN DE DRAAGCONSTRUCTIE – TWEE METHODEN *NOTE: De benodigde onderdelen voor het ophangen aan de draagconstructie zijn niet standaard inbegrepen.

- ① (UK) Direct to Structure (E) Fijación al forjado
- (F) Fixation à la structure (D) Direkt an der tragenden Decke
- (I) Direttamente alla struttura (NL) Rechtstreeks aan de draagconstructie

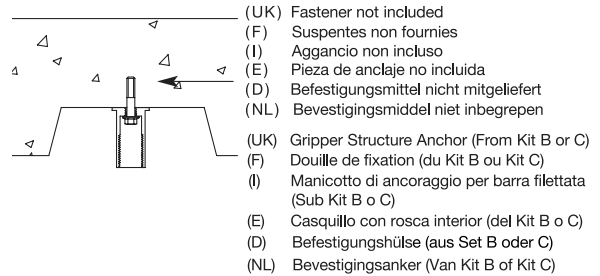

- (UK) Fastener not included
 - (F) Suspentes non fournies
 - (I) Aggancio non incluso
 - (E) Pieza de anclaje no incluida
 - (D) Befestigungsmittel nicht mitgeliefert
 - (NL) Bevestigingsmiddel niet inbegrepen
 - (UK) Gripper Structure Anchor (From Kit B or C)
 - (F) Douille de fixation (du Kit B ou Kit C)
 - (I) Manicotto di ancoraggio per barra filettata (Sub Kit B o C)
 - (E) Casquillo con rosca interior (del Kit B o C)
 - (D) Befestigungshülse (aus Set B oder C)
 - (NL) Bevestigingsanker (Van Kit B of Kit C)
- (UK) Attach the gripper structure anchor with a suitable fastener in accordance with EN13964.
 - (F) L'ancrage de la douille de fixation sera conforme à la norme EN13964.
 - (I) Collegare l'ancoraggio della struttura al tassello con un aggancio in conformità alla Norma EN13964.
 - (E) La fijación del casquillo al forjado debe ser conforme a la norma EN13964.
 - (D) Befestigungshülse (6 mm Innendurchmesser) mit Berücksichtigung der EN 13964 befestigen.
 - (NL) Bevestig het bevestigingsanker met een doelmatig bevestigingsmiddel volgens EN 13964.

- ② (UK) Below or through an existing ceiling
- (F) Sous un plafond existant
- (I) Al di sotto o tramite un soffitto esistente
- (E) Debajo o a través de un techo existente
- (D) Unter oder durch ein vorhandenes Deckensystem
- (NL) Onder een bestaand plafond of erdoorheen

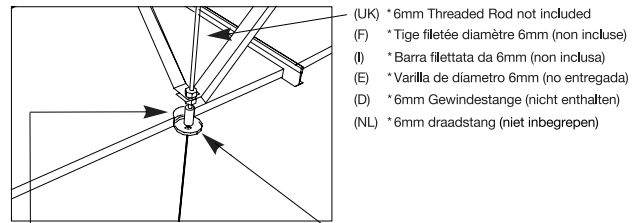

- (UK) *6mm Threaded Rod not included
- (F) *Tige filetée diamètre 6mm (non incluse)
- (I) *Barra filettata da 6mm (non inclusa)
- (E) *Varilla de diametro 6mm (no entregada)
- (D) *6mm Gewindestange (nicht enthalten)
- (NL) *6mm draadstang (niet inbegrepen)
- (UK) Gripper Structure Anchor
- (F) Douille de fixation
- (I) Manicotto di ancoraggio per barra filettata
- (E) Casquillo con rosca interior
- (D) Befestigungshülse
- (NL) Bevestigingsanker
- (UK) Escutcheon
- (F) Kit platine
- (I) Piastra di fissaggio
- (E) Platinas
- (D) Abdeckplatte
- (NL) Afdeekplaatje

- (UK) Kit D: Escutcheon Kit – BP7006
- (F) Kit D: Kit platine et son arrêt – BP7006
- (I) Kit D: Piastra e bulloni di fissaggio – BP7006
- (E) Kit D: Kit de platinas y elementos de fijación – BP7006
- (D) Set D: Abdeckplattenset – BP7006
- (NL) Kit D: Afdeekplaatje met bevestigingsaccessoires – BP7006

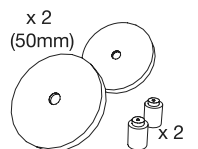

6

- (UK) LINKED CANOPIES
- (F) ASSEMBLAGE DE PLUSIEURS PANNEAUX CANOPIES
- (I) COLLEGARE I CANOPIES
- (E) ENSAMBLAR VARIOS PANELES
- (D) VERBINDUNG DER DECKENSEGEL
- (NL) VERBONDEN OVERKAPPINGEN

- (UK) **Kit E: Linking Kit** – BP7007
Links 2 canopies, side-by-side at one end.
- (F) **Kit de connexion pour 2 Canopies** – BP7007
Permet de relier 2 Canopies côte à côte
- (I) **Kit E: Kit di collegamento** – BP7007
Collegare 2 canopies, affiancati su un lato.
- (E) **Kit E: Kit de conexión** – BP7007
Ensamblar 2 canopies juntos
- (D) **Set E : Verbindungsset** – BP7007
Verbindet 2 Deckensegel nebeneinander an einer Seite
- (NL) **Kit E: Verbindingskit** – BP7007
Voor het zij aan zij verbinden van 2 overkappingen aan één kant.

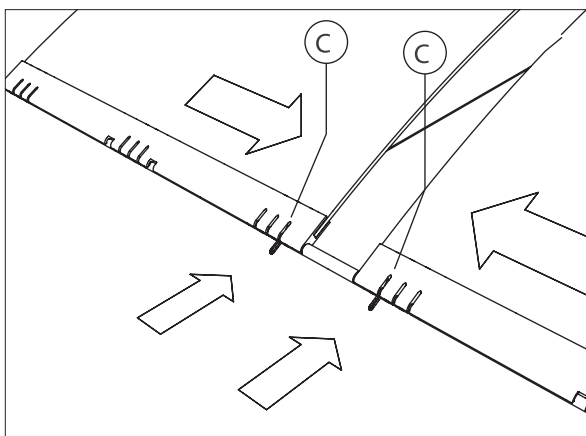
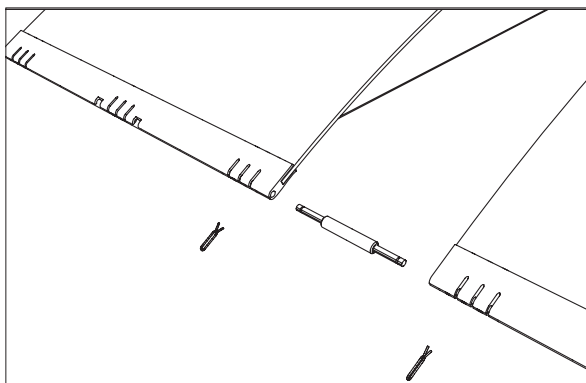
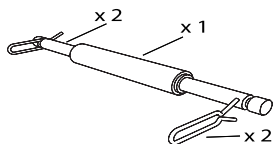

7

- (UK) WALL MOUNTING OF CANOPIES
- (F) FIXATION MURALE DES PANNEAUX CANOPIES
- (I) RACCORDO DEI CANOPIES ALLE PARETI
- (E) FIJACIÓN DE PANELES A LA PARED
- (D) BEFESTIGUNG DER DECKENSEGEL AN DER WAND
- (NL) WANDMONTAGE CANOPIES

- (UK) **Kit F: Wall Attachment Kit** – BP7008
Links and anchors 2 canopies side-by-side to a wall.
- (F) **Kit F: Kit de fixation murale** – BP7008
Permet d'accrocher des panneaux Canopies côte à côte sur un mur
- (I) **Kit F: Kit di raccordo alle pareti** – BP7008
Fissare i canopies affiancati alle pareti.
- (E) **Kit F: Kit de fijación a la pared** – BP7008
Ensamblar dos paneles y fijarlos a la pared
- (D) **Set F: Wandbefestigungs-Verbindungsset** – BP7008
Verankert Deckensegel nebeneinander an der Wand
- (NL) **Kit F: Wandbevestigingskit** – BP7008
Voor het zij aan zij verankeren van overkappingen aan een wand.

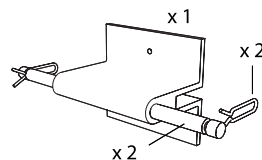

- (UK) **Kit G: Wall End Attachment Kit** – BP7009
Used at ends of single or linked canopies fixed to walls.
- (F) **Kit G: Kit d'embouts de fixation murale** – BP7009
- (I) **Kit G: Kit di raccordo alle pareti unilaterale** – BP7009
- (E) **Kit G: Kit de remate de pared** – BP7009
Se utiliza como remate en la conexión de uno o varios paneles a la pared
- (D) **Set G: Wandbefestigungsset** – BP7009
- (NL) **Kit G: Wandbevestigingskit uiteinde** – BP7009

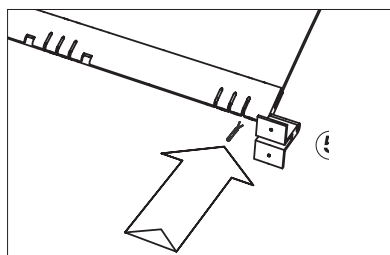
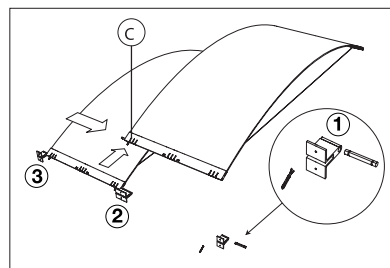
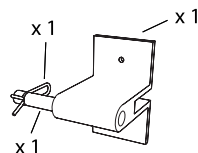



UK DESIGN LIMITATIONS

Infusions panels should always be installed in accordance with all applicable building codes and regulations.

Infusions cannot be drilled, cut or altered in any way.

Do not allow panel to get wet.

Do not place the panels in a damp or wet area, water may "wick" up through the panel.

We recommend that the lowest point of a suspended Infusions panel should be at least 2.25 metres above the finished floor surface.

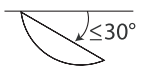

Canopies must be suspended with the extrusions level and the tensioning cables no more than 30° off horizontal.

Infusions panels are not recommended for external use.

Panel temperature should not be permitted to exceed 38°C after the tensioning cables have been installed.

Please contact our Internal Technical Sales Group for further details:  0800 371 849 (UK) and 1800 409 002 (ROI).

E RESTRICIONES

La instalación de los paneles Infusions siempre debe ser conforme a la norma de edificación.

El panel Infusions no debe ser taladrado, cortado, ni debe experimentar modificación de cualquier tipo.

El panel no debe tener contacto con agua.

No se deben colocar los paneles en áreas húmedas, el agua podría gotear por el panel.

Se recomienda que el panel esté suspendido a un mínimo de 2,25 metros del suelo.

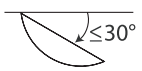

Los paneles cuelgan de los remates de aluminio y el ángulo máximo que soportan los cables de tensión es de 30 grados.

No debe instalarse en zonas exteriores.

Una vez tensados los cables, la temperatura del panel no puede superar los 38 grados.

Para más detalles, por favor, contacte con el Servicio de Información de Techos (+34) 91 642 04 99.

D DESIGN & INSTALLATIONSGRENZEN

Infusion Deckensegel sollen immer unter Berücksichtigung der örtlichen Bauregeln und Bauvorschriften montiert werden.

Die Deckensegel dürfen nicht angebohrt, eingeschnitten oder in anderer Form abgeändert werden.

Die Deckensegel sollten nicht naß werden.

Bereichen mit hoher Luftfeuchtigkeit sind zu meiden.

Wir empfehlen für den niedrigsten Punkt der Deckensegel eine Abhängöhe von 2,25m über dem fertigen Fußboden.

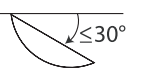

Die Deckensegel dürfen mit einem Winkel von maximal 30 Grad aus der Horizontalen montiert werden.

Sie sind nicht für den Außenbereich zugelassen.

Nach Montage der Paneele darf deren Temperatur 38° nicht überschreiten.

Weitere Informationen erhalten Sie von unserem Kundenservice. (+49) 0251 7603 210. Änderungen vorbehalten.

F RECOMMANDATIONS D'INSTALLATION

Les panneaux Infusions doivent toujours être installés conformément à la réglementation applicable au bâtiment.

Les Canopies ne doivent pas être percés, coupés, ou subir des transformations.

Le panneau ne doit pas être mouillé.

Les panneaux ne doivent pas être installés dans une zone humide.

Les panneaux Infusions ne doivent pas être installés à moins de 2.25 m du sol.

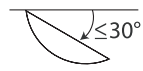

Les panneaux Canopies ne doivent pas former un angle supérieur à 30° une fois suspendus par ses câbles.

Ils ne doivent pas être installés à l'extérieur des bâtiments.

Après la mise sous tension des câbles d'installation, les panneaux ne doivent pas être exposés à une température supérieure à 38°C.

Pour de plus amples informations merci de contacter notre Service Info Conseil au 0800 413 643 (appel gratuit) .

I LIMITE DEL DESIGN

I pannelli Infusions dovranno essere installati a rispettando le normative in vigore.

Canopy non può essere avvitato, tagliato o alterato in nessuna maniera.

Il pannello non dovrà essere bagnato.

I pannelli non devono essere sottoposti a contatto con superfici che costituiscano fonti d'umidità.

Si raccomanda di non pendinare il pannello al di sotto di un'altezza di 2,25 m.

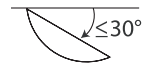

Dopo l'installazione dei cavi, i pannelli Canopies non dovranno superare un angolo di 30°.

I pannelli Infusions non dovranno essere utilizzati per esterni.

Dopo l'installazione dei cavi, la temperatura del locale non deve superare i 38°C.

Per ulteriori dettagli consultare il nostro Ufficio Commerciale (+39)02/66.22.76.50.

NL ONTWERPBEPERKINGEN

Infusions panelen dienen te allen tijde gemonteerd te worden conform alle relevante bouwverordeningen en -voorschriften.

In Canopies mag niet worden geboord, gesneden of op enige andere wijze worden aangepast.

Panelen mogen niet nat worden.

Als laagste hanghoogte voor een Infusions paneel wordt aanbevolen ten minste 2,25 meter boven het afgewerkte vloeroppervlak aan te houden.

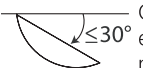

Canopies moeten opgehangen worden met de extrusies loodrecht en de spanningskabels mogen niet meer dan 30° van horizontaal afwijken.

Tevens zijn ze niet geschikt voor gebruik buiten gebouwen.

Nadat de spanningskabels geïnstalleerd zijn, mogen de panelen niet warmer worden dan 38°C.

Voor meer informatie kunt u contact opnemen met Market Service Center (+31) 076 521 77 33.

6

- (UK) LINKED CANOPIES
- (F) ASSEMBLAGE DE PLUSIEURS PANNEAUX CANOPIES
- (I) COLLEGARE I CANOPIES
- (E) ENSAMBLAR VARIOS PANELES
- (D) VERBINDUNG DER DECKENSEGEL AN DER WAND
- (NL) VERBONDEN OVERKAPPINGEN

- (UK) **Kit E: Linking Kit** – BP7007
Links 2 canopies, side-by-side at one end.
- (F) **Kit de connexion pour 2 Canopies** – BP7007
Permet de relier 2 Canopies côte à côte
- (I) **Kit E: Kit di collegamento** – BP7007
Collegare 2 canopies, affiancati su un lato.
- (E) **Kit E: Kit de conexión** – BP7007
Ensamblar 2 canopies juntos
- (D) **Set E: Verbindungsset** – BP7007
Verbindet 2 Deckensegel nebeneinander an einer Seite
- (NL) **Kit E: Verbindingskit** – BP7007
Voor het zij aan zij verbinden van 2 overkappingen aan één kant.

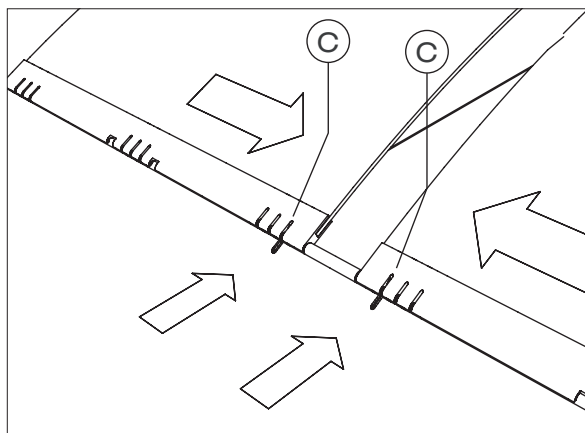
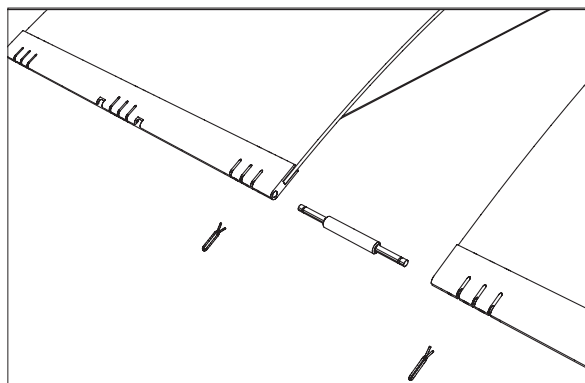
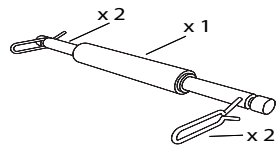

7

- (UK) WALL MOUNTING OF CANOPIES
- (F) FIXATION MURALE DES PANNEAUX CANOPIES
- (I) RACCORDO DEI CANOPIES ALLE PARETI
- (E) FIJACIÓN DE PANELES A LA PARED
- (D) BEFESTIGUNG DER DECKENSEGEL AN DER WAND
- (NL) WANDMONTAGE CANOPIES

- (UK) **Kit F: Wall Attachment Kit** – BP7008
Links and anchors 2 canopies side-by-side to a wall.
- (F) **Kit F: Kit de fixation murale** – BP7008
Permet d'accrocher des panneaux Canopies côte à côte sur un mur
- (I) **Kit F: Kit di raccordo alle pareti** – BP7008
Fissare i canopies affiancati alle pareti.
- (E) **Kit F: Kit de fijación a la pared** – BP7008
Ensamblar dos paneles y fijarlos a la pared
- (D) **Set F: Wandbefestigungs-Verbindungsset** – BP7008
Verankert Deckensegel nebeneinander an der Wand
- (NL) **Kit F: Wandbevestigingskit** – BP7008
Voor het zij aan zij verankeren van overkappingen aan een wand.

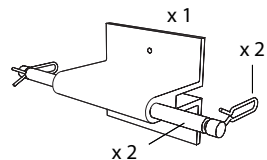

- (UK) **Kit G: Wall End Attachment Kit** – BP7009
Used at ends of single or linked canopies fixed to walls.
- (F) **Kit G: Kit d'embouts de fixation murale** – BP7009
- (I) **Kit G: Kit di raccordo alle pareti unilaterale** – BP7009
- (E) **Kit G: Kit de remate de pared** – BP7009
Se utiliza como remate en la conexión de uno o varios paneles a la pared
- (D) **Set G: Wandbefestigungsset** – BP7009
- (NL) **Kit G: Wandbevestigingskit uiteinde** – BP7009

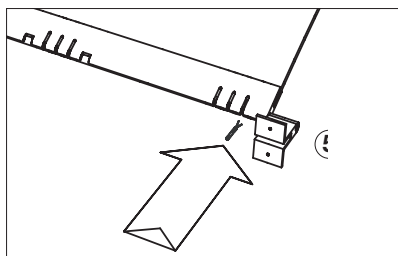
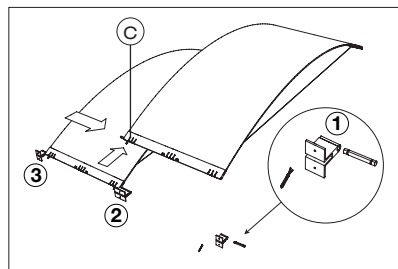
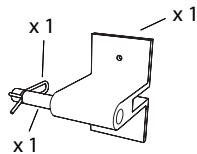

UK DESIGN LIMITATIONS

Infusions panels should always be installed in accordance with all applicable building codes and regulations.

Infusions cannot be drilled, cut or altered in any way.

Do not allow panel to get wet.

Do not place the panels in a damp or wet area, water may "wick" up through the panel.

We recommend that the lowest point of a suspended Infusions panel should be at least 2.25 metres above the finished floor surface.

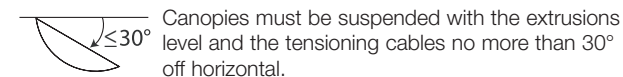

Infusions panels are not recommended for external use.

Panel temperature should not be permitted to exceed 38°C after the tensioning cables have been installed.

Please contact our Internal Technical Sales Group for further details: FREEPHONE 0800 371 849 (UK) and 1800 409 002 (ROI).

E RESTRICCIONES

La instalación de los paneles Infusions siempre debe ser conforme a la norma de edificación.

El panel Infusions no debe ser taladrado, cortado, ni debe experimentar modificación de cualquier tipo.

El panel no debe tener contacto con agua.

No se deben colocar los paneles en áreas húmedas, el agua podría gotear por el panel.

Se recomienda que el panel esté suspendido a un mínimo de 2,25 metros del suelo.

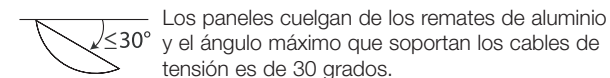

No debe instalarse en zonas exteriores.

Una vez tensados los cables, la temperatura del panel no puede superar los 38 grados.

Para más detalles, por favor, contacte con el Servicio de Información de Techos (+34) 91 642 04 99.

D DESIGN & INSTALLATIONSGRENZEN

Infusion Deckensegel sollen immer unter Berücksichtigung der örtlichen Bauregeln und Bauvorschriften montiert werden.

Die Deckensegel dürfen nicht angebohrt, eingeschnitten oder in anderer Form abgeändert werden.

Die Deckensegel sollten nicht naß werden.

Bereichen mit hoher Luftfeuchtigkeit sind zu meiden.

Wir empfehlen für den niedrigsten Punkt der Deckensegel eine Abhängöhe von 2,25m über dem fertigen Fußboden.

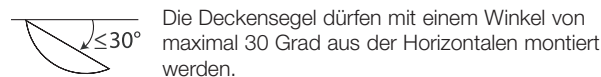

Sie sind nicht für den Außenbereich zugelassen.

Nach Montage der Paneele darf deren Temperatur 38° nicht überschreiten.

Weitere Informationen erhalten Sie von unserem Kundenservice. (+49) 0251 7603 210. Änderungen vorbehalten.

INFUSIONS™ CANOPY

F RECOMMANDATIONS D'INSTALLATION

Les panneaux Infusions doivent toujours être installés conformément à la réglementation applicable au bâtiment.

Les Canopies ne doivent pas être percés, coupés, ou subir des transformations.

Le panneau ne doit pas être mouillé.

Les panneaux ne doivent pas être installés dans une zone humide.

Les panneaux Infusions ne doivent pas être installés à moins de 2.25 m du sol.

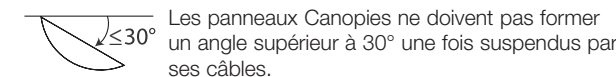

Ils ne doivent pas être installés à l'extérieur des bâtiments.

Après la mise sous tension des câbles d'installation, les panneaux ne doivent pas être exposés à une température supérieure à 38°C.

Pour de plus amples informations merci de contacter notre Service Info Conseil au 0800 413 643 (appel gratuit).

I LIMITE DEL DESIGN

I pannelli Infusions dovranno essere installati a rispettando le normative in vigore.

Canopy non può essere avvitato, tagliato o alterato in nessuna maniera.

Il pannello non dovrà essere bagnato.

I pannelli non devono essere sottoposti a contatto con superfici che costituiscano fonti d'umidità.

Si raccomanda di non pendinare il pannello al di sotto di un'altezza di 2,25 m.

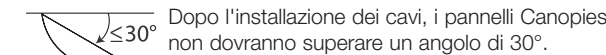

I pannelli Infusions non dovranno essere utilizzati per esterni.

Dopo l'installazione dei cavi, la temperatura del locale non deve superare i 38°C.

Per ulteriori dettagli consultare il nostro Ufficio Commerciale (+39)02/66.22.76.50.

NL ONTWERPBEPERKINGEN

Infusions panelen dienen te allen tijde gemonteerd te worden conform alle relevante bouwverordeningen en -voorschriften.

In Canopies mag niet worden geboord, gesneden of op enige andere wijze worden aangepast.

Panelen mogen niet nat worden.

Als laagste hanghoogte voor een Infusions paneel wordt aanbevolen ten minste 2,25 meter boven het afgewerkte vloeroppervlak aan te houden.

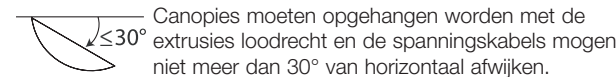

Tevens zijn ze niet geschikt voor gebruik buiten gebouwen.

Nadat de spanningskabels geïnstalleerd zijn, mogen de panelen niet warmer worden dan 38°C.

Voor meer informatie kunt u contact opnemen met Market Service Center (+31) 076 521 77 33.

1

- (UK) PANEL COMPONENTS (E) ELEMENTOS DE
(F) COMPOSANTS POUR UN FIJACIÓN DE UN PANEL
PANNEAU (D) PANEEL COMPONENTEN
(I) COMPONENTI DEL (NL) PANEELCOMPONENTEN
PANNELLO

- (UK) Kit A: Infusions Canopy Panel Kit
(F) Kit A: Kit Principal Infusions Canopy
(I) Kit A: Kit principale Infusions Canopy
(E) Kit A: Kit principal Infusions Canopy
(D) Set A: Basis Set
(NL) Kit A: Standaard kit voor een Infusions Canopy paneel

- (UK) (1) Flat Infusions Panel with extrusions attached
(F) (1) Panneau Infusions plat avec cornières en aluminium
(I) (1) Pannello Infusions piano con cornici in alluminio
(E) (1) Panel Infusions plano con remates de aluminio
(D) (1) Flaches Infusions Paneel mit Endschiene
(NL) (1) Infusions paneel met aangebrachte extrusies

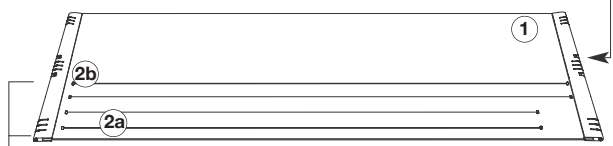

- (UK) (2a) & (2b) Cables to form arcs (60° or 90°)
(F) (2a) & (2b) Câbles permettant de former les arcs (60° ou 90°)
(I) (2a) & (2b) Cavi per creare la curva (60° o 90°)
(E) (2a) & (2b) Cables para dar curvatura al panel (60° o 90°)
(D) (2a) & (2b) Spannkabel zum erstellen der Bögen (60° oder 90°)
(NL) (2a) & (2b) Kabels om bogen te vormen (60° of 90°)

Infusions			
	1525 mm x 610 mm	1830 mm x 610 mm	
60°	(2a) 1473 mm	1770 mm	
90°	(2b) 1400 mm	1670 mm	

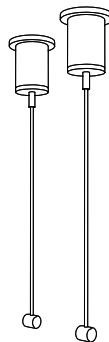

- (UK) Kit B - Standard 2.4m Hanging Kit - BP 7004A
(F) Kit B - Kit d'accrochage standard de 2.4m - BP 7004A
(I) Kit B - Kit di sospensione standard da 2.4m - BP 7004A
(E) Kit B - Kit de suspensión estándar 2.4m - BP 7004A
(D) Set B - Standard 2.4m Aufhangeset - BP 7004A
(NL) Kit B - Ophangkit ter verlenging (2.4m) - BP 7004A

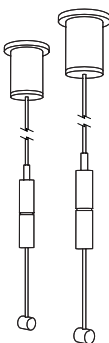

- (UK) Kit C - Extended 4.8m Hanging Kit - BP 7005A
(F) Kit C - Kit d'accrochage de grande hauteur (4.8m) - BP 7005A
(I) Kit C - Kit di estensione da 4.8m - BP 7005A
(E) Kit C - Kit de suspensión gran longitud (4.8m) - BP 7005A
(D) Set C - Extralanges Aufhangesets (4.8m) - BP 7005A
(NL) Kit C - Ophangkit ter verlenging (4.8m) - BP 7005A

2

- (UK) PANEL PREPARATION (E) PREPARACIÓN DEL PANEL
(F) PRÉPARATION DES (D) PANEEL MONTAGE
PANNEAUX (NL) PANEEL VOORBEREIDING
(I) PREPARAZIONE DEL PANNELLO

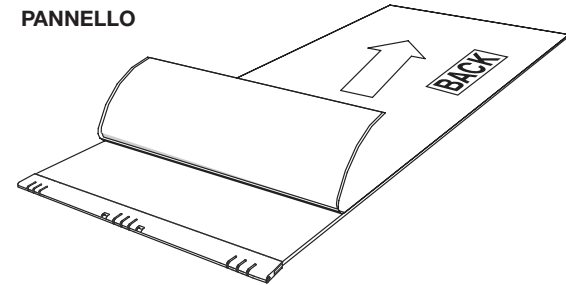

3

- (UK) PANEL ASSEMBLY (E) MONTAJE DEL PANEL
(F) ASSEMBLAGE DES (D) ERSTELLEN DES BOGENS
PANNEAUX (NL) BOGEN CREËREN
(I) ASSEMBLARE I PANNELLI

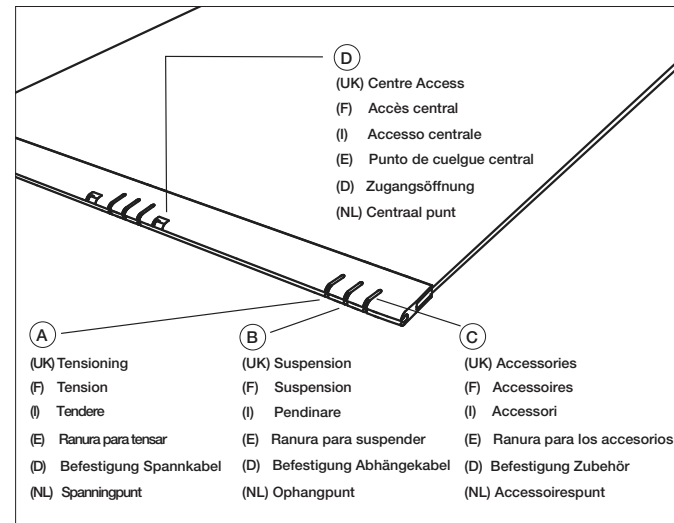

- (UK) Tensioning (UK) Suspension (UK) Accessories
(F) Tension (F) Suspension (F) Accessoires
(I) Tendere (I) Pendinare (I) Accessori
(E) Ranura para tensar (E) Ranura para suspender (E) Ranura para los accesorios
(D) Befestigung Spannkabel (D) Befestigung Abhängekabel (D) Befestigung Zubehör
(NL) Spanningpunt (NL) Ophangpunt (NL) Accessoirespunt

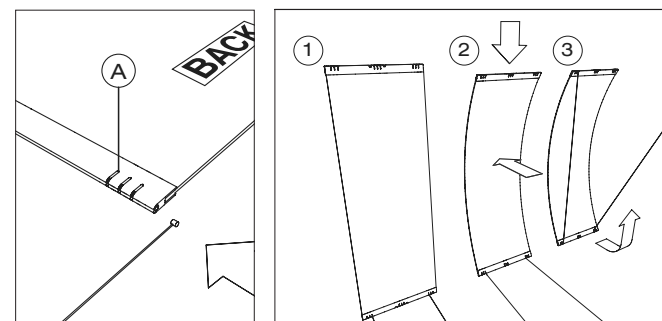

- (UK) Only use cables from Kit A for tensioning panels (Kit B and C are **only** for hanging panels).
(F) Utiliser les câbles provenant des Kit A pour cintrer les panneaux (les kits B et C servent seulement à les suspendre).
(I) Utilizzare **solo** i cavi del kit A per tendere i pannelli. (i kit B e C vengono utilizzati solo per sospendere i pannelli).
(E) Para tensar el panel debe **IMPERATIVAMENTE** utilizarse los cables del Kit A (los cables del Kit B y Kit C son para la suspensión).
(D) Nutzen Sie **nur** die Kabel aus Set A um die Panele zu spannen (Set B und C sind **nur** um die Panele aufzuhängen).
(NL) Gebruik voor het spannen van panelen uitsluitend kabels uit Kit A (de kabels uit Kit B en C zijn uitsluitend bestemd voor het ophangen van panelen).

4

- (UK) INSERTING SUSPENSION CABLES
(F) INSERER LES CABLES DE SUSPENSION
(I) INSERIRE I CAVI DI SOSPENSIONE
(E) MONTAJE DEL CABLE DE SUSPENSIÓN
(D) VERBINDEN DER ABHÄNGEKABEL
(NL) HET BEVESTIGEN VAN DE OPHANGKABELS

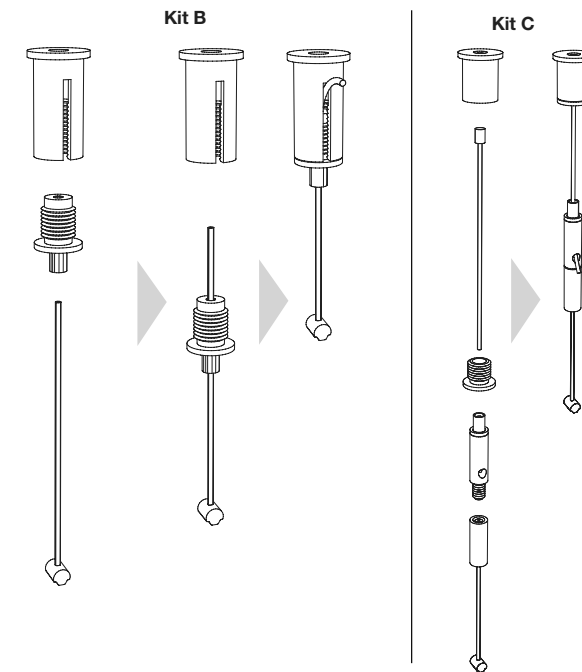

- (UK) The maximum allowable deflection is 5 degrees. Substitute Kit C when cables meet the structure at an angle.
(F) Un angle de 5° maximum est autorisé. Au delà, il convient d'utiliser un Kit C, si les câbles sont en contact avec la structure.
(I) La freccia massima è di 5 gradi. Al di sopra, si consiglia di utilizzare il Kit C quando i cavi vengono a contatto con la struttura.
(E) La máxima desviación permitida con respecto al eje vertical es de 5 grados. Más allá, se recomienda utilizar el kit C, cuando los cables se fijan al forjado en un ángulo.
(D) Bei Set B dürfen die Kabel nur lotrecht an die Befestigungshülsen anschließen. Die maximale Abweichung ist 5 Grad. Set C ist zu benutzen, wenn das Kabel mit einer größeren Abweichung am Befestigungspunkt anschließt.
(NL) Bij gebruik van kit B moeten de kabels mogen loodrecht hangen. De maximale toegestane hoek is 5°. Vervang Kit B door Kit C als de hoek groter is.

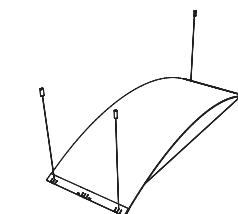
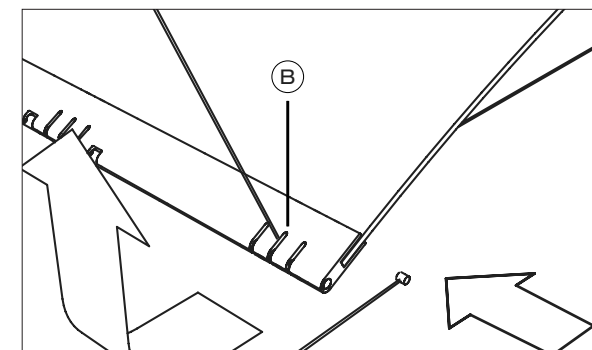

5

- (UK) ATTACHING CANOPIES TO THE STRUCTURE - TWO METHODS *
*NOTE: Fasteners required for attachment to the structure are not included in any Infusions kits since the type required will vary by building structure.
(F) FIXATION DES INFUSIONS CANOPIES À LA STRUCTURE - 2 MÉTHODES *Nota: Les suspentes ne sont pas fournies dans les Kits Infusions, celles-ci pouvant être différentes en fonction du type de structure du bâtiment.
(I) PENDINARE I CANOPIES ALLA STRUTTURA - DUE METODI *
*NOTA BENE: Gli accessori necessari per pendinare i canopies alla struttura non sono inclusi nel kit di installazione - in quanto dipendenti dal tipo di dalla struttura.
(E) FIJACIÓN AL FORJADO - DOS MÉTODOS *
*NOTA: Las piezas de cuelgue necesarias para la fijación al forjado no forman parte de los elementos entregados en los Kits puesto que estas piezas pueden variar según la estructura del edificio.
(D) BEFESTIGUNG DER DECKENSEGEL AN DER TRAGSTRUKTUR - ZWEI MÖGLICHKEITEN*
*HINWEIS: Befestigungsmittel für die Montage an der Tragstruktur werden nicht mitgeliefert da sie unterschiedlich sein können.
(NL) DE CANOPIES BEVESTIGEN AAN DE DRAAGCONSTRUCTIE - TWEE METHODEN *NOTE: De benodigde onderdelen voor het ophangen aan de draagconstructie zijn niet standaard inbegrepen.

- 1 (UK) Direct to Structure (E) Fijación al forjado
(F) Fixation à la structure (D) Direkt an der tragenden Decke
(I) Direttamente alla struttura (NL) Rechtstreeks aan de draagconstructie

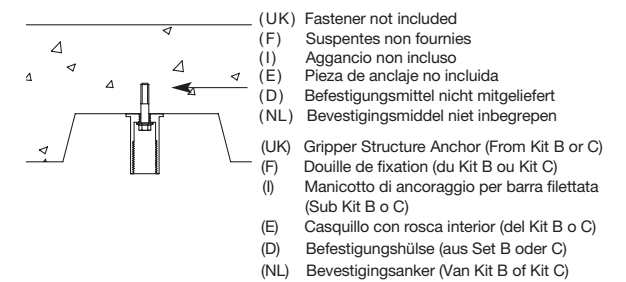

- (UK) Attach the gripper structure anchor with a suitable fastener in accordance with EN13964.
(F) L'ancrage de la douille de fixation sera conforme à la norme EN13964.
(I) Collegare l'ancoraggio della struttura al tassello con un aggancio in conformità alla Norma EN13964.
(E) La fijación del casquillo al forjado debe ser conforme a la norma EN13964.
(D) Befestigungshülse (6 mm Innendurchmesser) mit Berücksichtigung der EN 13964 befestigen.
(NL) Bevestig het bevestigingsanker met een doelmatig bevestigingsmiddel volgens EN 13964.

- 2 (UK) Below or through an existing ceiling
(F) Sous un plafond existant
(I) Al di sotto o tramite un soffitto esistente
(E) Debajo o a través de un techo existente
(D) Unter oder durch ein vorhandenes Deckensystem
(NL) Onder een bestaand plafond of erdoorheen

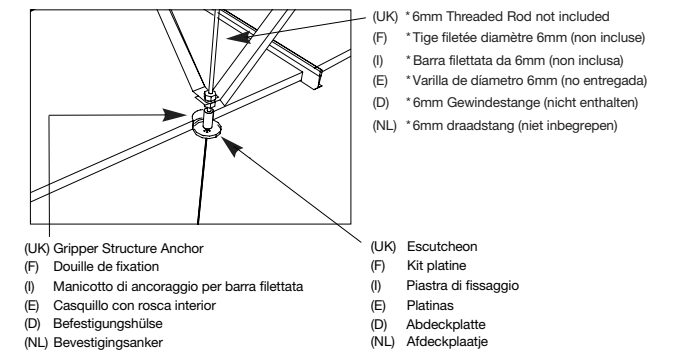

- (UK) Kit D: Escutcheon Kit - BP7006
(F) Kit D: Kit platine et son arrêt - BP7006
(I) Kit D: Piastra e bulloni di fissaggio - BP7006
(E) Kit D: Kit de platinas y elementos de fijación - BP7006
(D) Set D: Abdeckplattenset - BP7006
(NL) Kit D: Afdekplaatje met bevestigingsaccessoires - BP7006

